

Bioplastics Lab

Learning Objectives:

- Gained an understanding of the polymerization process.
- Gained an understanding of bioplastics and their uses.
- Gained an understanding of bioplastics' challenges and opportunities.
- Developed and processed different bioplastic products.
- Developed and tested bioplastic properties.
- Gained "hands-on" experience in the preparation, processing, and testing of different bioplastics.

Learning Outcomes:

- Define a bioplastic
- Explain the challenges and opportunities associated with bioplastics
- Explain and illustrate the polymerization process.
- Discuss current uses of bioplastics.
- Discuss the history, chemistry and physical properties of bioplastics
- Discuss the environmental and sustainability aspects of bioplastics

Pre-Lab

Background

Background Information

Timing

Imagine this: It is the day after graduation, and you are about to drive off the parking lot of a car dealership in your brand new Ford Mustang. The seats of your car are made of soy foam, and your car is powered by gasoline made from plants. Ahhh... You sip water from a bottle made from corn after finishing a call on your Samsung Reclaim bioplastic cell phone. You are feeling good about your new freedom and about the number of eco-friendly elements comprising your car. As you pull off, you imagine Henry Ford himself giving you the thumbs up on your new ride. Why? Well, in addition to creating the first automobile, Ford invented in 1941 what might be considered the first green car. The materials comprising Ford's soybean car were made with hemp, wheat, flax, and soybeans. Unfortunately, poor timing kept the car from ever hitting the road. Shortly after the soybean car made its debut, the United States became involved in World War II. Auto production ground to a halt, as workers shifted to building jeeps and tanks. Ford's idea of making plastic from plants was all but forgotten until the 1990s, when people seeking to protect the environment started developing alternatives to conventional, petroleum-based plastic. Today, there is a new breed of car seats, water bottles, and cell phones that are among hundreds of plastic items being promoted as "green"—that is, less harmful to the environment. These items are made of plant-based plastics called bioplastics that could make up 20% of the plastics market by 2020.



Courtesy of Samsung

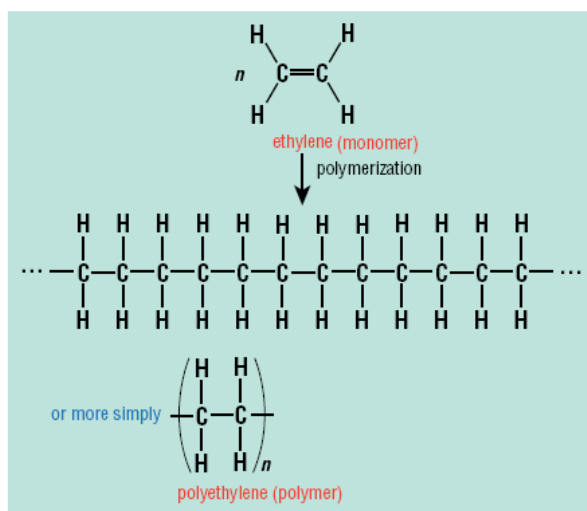

Figure 1. Polymerization of ethylene into polyethylene (n is a large number.)

Plastics

Many materials that we use in our everyday life are made of plastics. But what are these plastics made of? Plastics belong to a group of molecules called polymers, which are large molecules made of repeating units called monomers. Most plastics contain between 500 and 20,000 or more repeating units. Plastics can be produced by bonding together monomers in a reaction called polymerization. For example, a plastic called polyethylene, which is commonly used in grocery bags and packaging, is formed by adding together molecules of ethylene (C_2H_4) (Fig. 1). Most plastics are made from crude oil. Molecules present in crude oil undergo chemical reactions that create monomers, which are assembled together to make polymers that can be processed into plastics. This process is very common, but it produces pollutants, such as carbon dioxide (CO_2), which contribute to climate change. Also, crude oil is in great demand throughout the world. Scientists estimate that at today's consumption rate, the world's oil supply may dry up in less than 100 years. To address these two problems, scientists have been looking for the past two decades for new ways of making plastics. One way involves the

use of plants as the raw material, instead of crude oil. This type of plastic is called bioplastic.

Bioplastics

Bioplastics are made by converting the sugar present in plants into plastic. In the United States, that sugar comes from corn. Other countries use sugar cane, sugar beets, wheat, or potatoes. This makes bioplastics renewable and better for the environment than conventional plastics. Two types of bioplastics are now produced in large quantities. They are called polylactide acid (PLA) and polyhydroxyalkanoate (PHA). The biggest producer of PLA is NatureWorks, a company located in Blair, Neb. There, corn kernels are milled, a chemical substance called dextrose is extracted, and dextrose is fermented by bacteria or yeast in big vats. The result is lactic acid (Fig. 2), which acts as a repeating unit to make PLA.

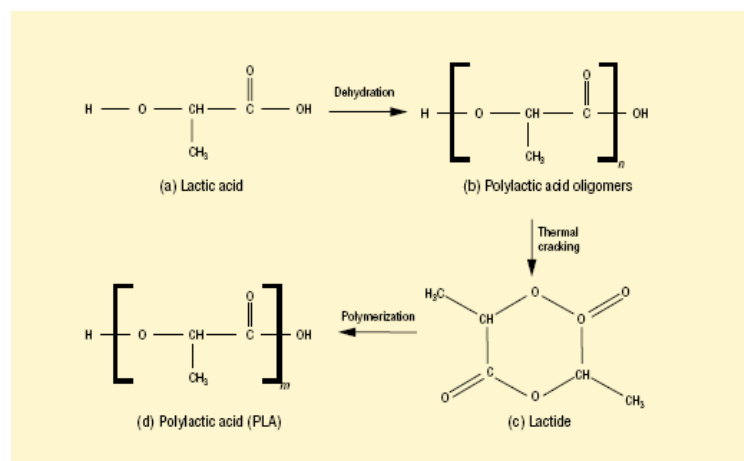

Figure 2. Production of polylactic acid (n and m are large numbers.)

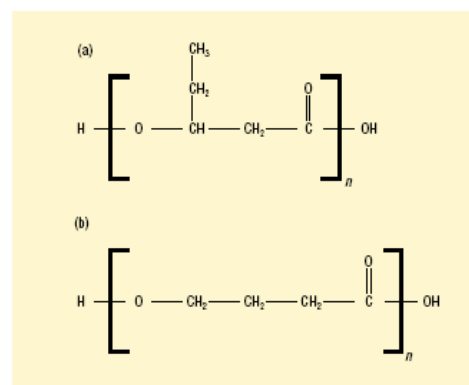

Figure 3. Examples of two PHA molecules: (a) poly-3-hydroxyvalerate; (b) poly-4-hydroxybutyrate (n is a large number.)

But lactic acid cannot be directly polymerized into PLA because the chemical reaction that bonds two molecules of lactic acid together also generates water. The water molecules prevent the growing chain of lactic acid molecules from staying together. So, instead of a long chain of lactic acid molecules, many small chains are formed. They are called polylactic acid oligomers (Fig. 2b)—in which “oligomer” means “small chain.” These small chains are processed in a chemical reaction that leads to smaller lactide molecules (Fig. 2c). The chemical reaction also produces water, which is later eliminated. The lactide molecules act as monomers that are polymerized into PLA (Fig. 2d) in a process similar to the polymerization of ethylene into polyethylene. The other common bioplastic, PHA, is a polymer produced naturally by bacteria. Different PHA molecules are made by the bacteria. These molecules can consist of more than 150 different types of monomers, leading to materials with very different properties from one another. Two types of PHA polymers are shown in Fig. 3, formed in polymerization reactions that combine more than 150 different types of monomers, leading to materials with very different properties. Two PHA polymers are shown in Fig. 3.

One of the most common consumer products that use bioplastics is the disposable water bottle. The new Dasani "Plant Bottle" is made of 30% plant material. The rest is petroleum-based polyethylene terephthalate, the same plastic used in conventional plastic bottles. Primo water bottles, on the other hand, are made entirely from corn starch.



Background Information II ***Environment***

Are bioplastics good for the environment?

Are plant-based plastics every environmentalist's dream? Some ads for bioplastics may make it seem so, especially when these ads claim that bioplastics generate no waste and produce no pollutants. Let's examine the facts. Some environmentalists point out hidden environmental costs, such as toxic pesticides sprayed on the crops and carbon dioxide emissions from harvesting vehicles. Also, some manufacturers of bioplastics claim that making them does not use up fossil fuels—oil, natural gas, and coal. This is not always true. Although fossil fuels are not used to make many bioplastic products, they are typically used to power manufacturing plants. And producing bioplastics often requires nearly as much energy as producing conventional plastics.

Composting bioplastics

A number of bioplastics, including those made with PLA, are "compostable": Give them enough heat, moisture, and hungry microbes, and the microbes will break them down into plant material, carbon dioxide, and water. It is the carbon dioxide that concerns some environmentalists.

“This carbon dioxide gas goes back into the atmosphere,” says Richard Wool, a chemical engineer at the University of Delaware in Newark. “So, composting bioplastics seems like a misguided solution.” Nearly all compostable plastic ends up in a landfill instead of being composted. Like other plastics, bioplastics remain intact, buried in the oxygen-free environment of landfills. But some scientists worry that over many years; bioplastics will slowly decompose, giving off methane (CH₄), a greenhouse gas 20 times more potent than carbon dioxide.

For example, in a landfill, PLA would degrade according to the following reaction:

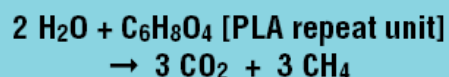

The landfill dilemma is unavoidable at a time when only a few parts of the country have the industrial composting facilities needed to break down bioplastics. Also, ineffective labeling keeps many compostable plastics out of the composting mix. Robert Reed, public relations manager for San Francisco's Sunset Scavenger Company, a private corporation that handles the city's waste recycling and composting, explains that his company's employees remove anything that looks like it doesn't belong with the compostable food scraps and yard waste. “Unless it's clearly marked, it would be impossible for sorting workers to know it's a compostable cup,” he said. “The industry needs to more clearly label and identify them.” Recycling offers an alternative, but it is not so easy. Products made from recycled plastics will hold together only if they are made from plastics of the same type. Also, because various plastic types have different melting points, recycling a mixture of plastics is not possible.

Room for improvement

PLA and PHA are innovative, but with lots of room for improvement. Chemists are already busy creating the next generation of bioplastics. “The use of corn today is just a stepping stone,” said Steve Davies, NatureWorks' director of corporate communications. The new bioplastics will look like conventional plastic and will have less environmental impact than their predecessors. They will be produced in factories powered by wind, the sun, biofuels, and other renewable energy sources, further shrinking their impact on the environment. Within 10 years, Davies **expects his** company to move from corn to abundant nonfood crops such as switchgrass. Competitor Metabolix announced in August 2008 that it had genetically engineered switchgrass to produce PHA within its leaves. Once the plastic particles are extracted, with a solvent, the remaining switchgrass could be used to produce fuel, cutting waste down to almost nothing. In the meantime, you can do something to reduce plastic's harmful impact on the environment. It does not cost any money and does not require composting or recycling: “Don't use disposable,” said Chris Peck, director of public affairs for the California Integrated Waste Management Board. “What's better than a plastic fork? A metal fork. If you reuse things, you are not throwing them away.”

References:

Gerngross, T.; Slater, S. How Green Are Green Plastics? *Scientific American*, Aug 2000.
Ziegler, J. Metabolix Defies Skeptics With Plastic From Plants (Update 2),
Bloomberg.com: <http://www.bloomberg.com/apps/news?pid=co>
newsstory&tkr=MBLX:US&sid=a14PM9E9M4r4 [Aug 2009] **Cynthia Washam** is a
science writer in Jensen Beach, Fla. This is her first article in *ChemMatters*.

Posted: September 16, 2010

From the September 2010 Issue of *Plastics Engineering*:

HOW GREEN IS MY VEHICLE?

By Nancy D. Lamontagne

Economies are struggling, and car manufacturers are working hard to improve fuel efficiency and diminish environmental impacts without increasing costs. Replacing heavier metal parts with plastic ones can improve fuel efficiency by making cars lighter. And the auto industry is developing and testing new lightweighting materials and ways to increase recycled and biobased materials so that cars can be more eco-friendly.

The pressure for increased fuel efficiency comes from consumers as well as government. In April, U.S. President Barack Obama announced rules mandating that by the 2016 model year, vehicles should reach a fleet average of 35.5 miles per gallon, and in May he signed a memorandum ordering federal agencies to begin work on stronger fuel efficiency standards for model-year 2017 vehicles and beyond.

“In the future, weight reduction and cost will be the biggest drivers,” says Jay Hutchins, director of Marketing and Product Planning, Interior Systems, Faurecia North America. “All automakers are focused on reducing as much weight as they can from the vehicle to meet the new Corporate Average Fuel Economy (CAFE) standards. Weight is the most direct link to fuel consumption, and we are working hard to offer new materials to help reduce the weight of the products we supply.”

Faurecia supplies seating, emissions control technologies, interior systems, and exteriors for major automakers, including the Volkswagen Polo BlueMotion, reportedly the world’s most fuel-efficient car and 2010 “World Green Car of the Year.” Hutchins says that Faurecia’s products account for 15% to 20% of a vehicle’s weight. “Faurecia innovations will allow us to reduce the weight of our products by as much as 30% by 2020—twice the weight savings we anticipated just one year ago.”

Though plastics are already quite apparent in car interiors, new materials and new designs can still decrease weight in this area. For example, the new design approach of

the company's Sustainable Comfort 1.5 incorporates a thin seat with an ultra-thin back, providing more interior space, easier recycling, and greater flexibility for vehicle designers. Plastics are going into places that haven't been thought of before, such as a new structural carrier that replaces the conventional wire frame of the back seat. "This seat is more comfortable than most other rear seats, can easily incorporate lighting and storage, and weighs less than standard seats because its structure reduces the amount of required polyurethane foam and trim covers," says Mike Miner, product planning manager, Automotive Seating, Faurecia North America.

Will CFRP Go Mainstream?

Carbon fiber-reinforced plastic (CFRP) has proven strong enough to increase the fuel efficiency of aircraft and to help racecars go faster. This material still faces some challenges, but carmakers are beginning experiment with it in some low-production, high-end cars.

For example, the Lexus "F" premium sports car series will incorporate CFRP from Toho Tenax, the core company of Teijin Group's carbon fiber business. According to Toho Tenax, the cabin will be 65% CFRP, reducing its weight by 100 kg below that of a similar aluminum cabin but without sacrificing rigidity. The composite will be used for the diffuser, speed-controlled rear wing, and interior components. The car series will be marketed at the end of this year.

Kalyan Sehanobish, senior scientist at Dow Chemical Co., gave a presentation on the CRFP at last year's SPE Automotive Composites Conference and Exhibition. He said that for CRFP to become a mainstream material in future cars, carbon fiber must reach a steady cost of \$4/lb to \$5/lb with ample supply, cars must use monocoque designs or integrate multifunctional features, fabricators must produce parts at 2-minute to 4-minute cycle times, and significant investment must move away from metal-based assembly. A strong partnership of producers, fabricators, and OEMS is necessary to meet these requirements, he said.

Sehanobish says that the extent to which CFRP can help in lightweighting cars will depend on how many car parts the OEM converts from metal to composites and on the metal used in the original part (aluminum versus steel). For example, about 20% improvement in fuel economy could be achieved if CFRP were used to reduce vehicle weight by about 60% without any engine redesign. However, he says, no car currently uses this much CFRP.

The composite can improve crashworthiness by absorbing more energy during a crash. Sehanobish says that durable CFRP parts that are cost-effective and crashworthy can be built if the body structure is integrated with the body panel (monocoque), as opposed to stamping out many small parts and assembling them, as is currently done with metal car parts. "Today, for 100,000 or more parts per year, CFRP technology is not cost competitive with metals," he says. "The more functions a single CFRP part can provide, the more opportunity there is for cost reduction."

To help advance CFRP, Dow is collaborating with Oak Ridge National Laboratory to develop low-cost carbon fiber and is participating in CFRP development programs with external laboratories and supporting industries in the European Union and the U.S. Beyond CFRP, the company is continuously introducing lightweight plastic parts, replacing welds with crash-durable adhesives, and filling metal cavities with lightweight foams for structural and acoustic purposes.

Lightweighting Electric Cars

SGL Automotive Carbon Fibers LLC, a joint venture of the BMW Group and SGL Group, is taking a step toward reducing CRFP cost with a fiber plant they are building in Moses Lake, Washington, USA. The facility is part of the companies' strategy to commercialize viable manufacturing of carbon fiber-reinforced plastics for future vehicles. The companies say they want to produce carbon-fiber products in large volumes and at competitive costs.

The plant will convert polyacrylic fibers into carbon fibers, one step in CFRP production. The fibers will be used in CFRP for BMW's upcoming Megacity vehicle, which is planned for a 2013 launch. The battery electric vehicle will be manufactured in high series quantities.

Andreas Wuellner, managing director of SGL Automotive Carbon Fibers, says that the main advantages of CFRP are its lightness, stiffness (about three times higher than aluminum), and tensile strength (about four times greater than steel). "These advantages are key drivers for the application in vehicles," he says. "However, these are even more relevant to the design of a battery electric vehicle. The weight increase of the lithium ion batteries calls for additional weight savings."

Wuellner adds that the need for CO₂ reduction and thus for lightweight design is increasing. "We are convinced that the automotive industry will follow our example and will introduce CFRP parts into series production in future."

Safer Than Steel

Safety is an important factor when replacing metal with a new material. Researchers from Nihon University in Japan recently developed a numerical method to compare a CFRP guarder belt for a car door with one made with steel. This belt reinforces the door during a side collision. They studied this application of CFRP because the material is not only light and strong but also has high energy absorption, says Professor Yoshio Aoki.

The Nihon group found that although the experimental energy absorption of the CFRP guarder belt is smaller than that of the conventional impact beam, the specific energy absorption of the CFRP belt is 30 times more than that of the beam. The researchers say that this means that increasing the thickness and width of the CFRP belt could yield an energy absorption that is more than that of the steel impact beam.

For the CFRP belt to find use, a method of mass-producing it must be examined. "I think it may find use in luxury cars if fuel cost improvement and enhanced safety by car lightening become more important," Aoki says. The researchers are now examining CFRP energy-absorbing properties of parts undergoing a frontal impact accident as well as the energy-absorption of beam parts made from CFRP hybridized with aluminum alloy.

Aoki says that one advantage of CFRP is that it can be used for large-scale parts made by resin transfer molding, greatly reducing the number of necessary parts. To succeed, he says, the cost of manufacturing needs to decrease and mass production technology must be established.

Green Goes In

As car manufacturers look for ways to make their manufacturing processes environmentally friendly, incorporating recycled, recyclable, and biobased plastics not only can be environmentally responsible but also can save money.

Ford, for example, saved approximately \$4.5 million in 2009 by using recycled materials, keeping 25 to 30 million lbs of plastic out of North American landfills. The company uses post-consumer recycled resins such as detergent bottles, tires, and battery casings to make underbody systems such as aerodynamic shields, splash shields, and radiator air deflector shields.

Biobased materials such as soy-based polyurethane can reduce petroleum oil usage. Ford uses the material on seat cushions and seatbacks of 23 of its vehicle models. The Escape also sports a soy-based headliner. The company says that the 2 million Ford, Lincoln, and Mercury vehicles with biofoam seats on the road today already have reduced petroleum oil usage by more than 3 million lbs.

The company is studying natural fibers as a potential substitute for the glass fibers traditionally used to reinforce plastic car parts that reduce vehicle weight. Such natural fiber composites are more eco-friendly, because their production is less energy-intensive than glass fibers, and they are more recyclable. The company is looking at a wide variety of fibers, including sisal, hemp, Indian grass, coconut coir, and wheat straw.

Polypropylene filled with wheat straw, an agricultural byproduct, has already made its way into the third-row bins of the 2010 Flex. The material, which is 20% wheat straw, was developed in conjunction with the Ontario BioCar Initiative, a partnership involving the automotive industry, four Canadian universities, and the Canadian government that is aimed at accelerating the use of biomass in automotive materials.

"We would like to see this material migrated to other interior automotive applications in the future," says Debbie Mielewski, polymer technical leader at Ford Motor Co. "The Flex bins alone save about 20,000 lbs of petroleum each year and reduce CO₂ emissions by 30,000 lbs."

Natural fibers in cars today are typically used in compression-molded plastic parts. “Unfortunately, most plastic car parts are injection molded, and that’s where our work on natural fibers has concentrated,” Mielewski says. “We can make a huge impact if we can overcome the challenges in using natural fibers for injection-molded parts.”

The challenges for using natural fibers instead of traditional fillers for plastics depend on the particular application. Natural fibers have an inherent tendency to absorb moisture, which reduces the mechanical properties (such as stiffness) of the composite and makes it heavier. Moisture absorption is typically a problem when the fiber is embedded in polar polymer matrices such as nylon or polyesters. The fiber’s odor during part processing or service must be considered as well as its consistency, which can change with growing season conditions. In addition, the supply chain for natural fibers is not established.

It is going to take some time as well as research and development before natural fiber-reinforced plastics are as strong as carbon-reinforced materials,” Mielewski says. With some fiber and plastic combinations, the company is getting close to matching glass fiber composites with natural fibers. “We must make sure that the composite performs equally to the traditional material that it is replacing; there can be no compromise in quality or long-term durability,” she says.

Some of the biobased materials are lighter in weight than the materials they replace, helping improve fuel economy. Many of the biomaterials use less energy to produce and process. “Our work in biomaterial development is complementary to the work in fuel economy and alternative powertrains,” Mielewski says. “We have to keep learning and apply what we’ve learned to utilize the best technology available at the time.”

Strong and Heat-Resistant Biomaterials

Mazda Motor Corp. has been developing new eco-friendly materials for use in its cars. The company says that to work well in cars, bioplastics must be strong (to absorb shock) and heat-resistant. Mazda was part of a research project involving industry, academia, and local government in Hiroshima, Japan, that created a bioplastic with the strength, heat resistance, and quality finish necessary for injection-molded automobile interior parts.

The bioplastic was made from polylactic acid extracted from plants; over 80% of its content was plant-derived. Altering the polylactic acid’s molecular structure to raise its melting point and developing a compatibilizer compound that helped disperse the shock-absorbing flexible ingredients increased the bioplastic’s strength and shock absorbance.

According to Mazda, the bioplastic had three times the shock impact resistance and 25% higher heat resistance than contemporary bioplastics used for items such as electrical appliances. In addition, rather than be limited to press-forming only, the material can be extrusion-molded, making it usable for more car parts. This bioplastic was used in the Premacy Hydrogen RE Hybrid’s instrument panel and other interior fittings.

Mazda is also working on bioplastic made from non-food-based biomass such as plant waste and wood shavings, hoping to have it ready for car use by 2013. The goal is to create a versatile polypropylene with enough heat resistance, strength, and durability for vehicle bumpers and instrument panels. The biomass will be converted to ethanol, and then researchers will investigate various mixtures of ethylene and propylene. The project will also work to optimize an eco-friendly and cost-effective process for manufacturing the plastic.

Green to the End

Green manufacturing doesn't stop in the production plant; carmakers are working to make sure that the cars can be easily recycled at the end of their lifecycles. The European Union's End of Life Vehicles (ELV) Directive adopted in 1997 is one motivation for manufacturers. It aims at making vehicle dismantling and recycling more environmentally friendly; sets clear targets for reuse, recycling, and recovery of vehicles and their components; and also encourages manufacturers to keep recyclability in mind as they create new vehicles.

At the end of its life, the usable parts on a vehicle are removed. Larger parts such as plastic bumpers, for example, can be removed, crushed, and pelletized to be used to make car parts. Mazda has been studying how best to remove paint from the plastic in these bumpers. The conventional process removes 98.50% of paint, but new bumpers containing 30% of this recycled material didn't have a surface quality good enough for painting. Mazda researchers determined that making a bumper containing 30% recycled material would require removing 99.85% of the paint, and they have developed a method that achieves that percentage.

After the usable parts of a vehicle have been removed, the remaining material is usually shredded. The metals are recycled and the leftover shredder residue goes to a landfill. Argonne National Laboratory has developed a process that separates the many types of polymers in the residue so that the individual plastics can be reused or recycled instead.

Bassam J. Jody, a principal engineer/project manager in the process technology research area of Argonne National Laboratory's Energy Systems Division, points out that recycling these plastics is important because the use of plastics and composites in vehicles has been increasing. Although metals are now profitably recycled, most nonmetal car parts, including plastics, end up in landfills.

"When plastics are landfilled, more have to be made from petroleum products, which consumes more energy and generates more greenhouse gases," Jody says. "In addition, recycling increases material availability to the end users at prices less than virgin material prices."

The process developed at Argonne can separate plastics from the residue with a purity of 95% or higher. The plastics are concentrated by mechanical separation, and then

separated with novel sink or float techniques including froth flotation, which separates hydrophobic and hydrophilic materials.

Argonne developed a 2-ton-per-hour pilot plant to determine optimal operating conditions and process economics. A shredder company has built a 20 ton/hr validation plant that is undergoing testing and evaluation. It is expected to be operational in a few months.

Bioplastics: Structure, Chemistry, Industry and Environment

(This activity was created by Dr. Robert Anex and Alison Oglethorpe. The extension activity was developed by Robert Kinsey, Autumn Thigpen, and Steve Barrett.)

The Bronze Age of Bioplastics

Bioplastics date back to the Bronze Age, but they are due for a comeback as our modern hunger for petroleum exceeds the available supply. As people cut back on the use of petroleum based products, a new solution will need to be found. By using natural, abundant, biodegradable materials (such as gelatin or starch), new non-petroleum based plastics can be made. The term bioplastic comes from the need to mark these types of plastics separately from their more common oil-based cousins.

Polymer Structure

Polymers can be classified as fibers, elastomers, or plastics. The classification is dependent upon how the atoms in a molecule are aligned or hooked together. In primary valence bonding, the atoms are hooked together using their valence electrons. An example of valence bonding is covalent bonding. The secondary bonding of the atoms does not involve the valence electrons. The secondary bonding is called secondary valence forces. It is responsible for the force of attraction between individual molecules. Examples of secondary valence forces are hydrogen bonds and dipole – dipole bonding. Secondary bonding is weaker than primary bonding; therefore, the molecules must come close together for secondary bonds to have an effect. The close alignment of the molecules depends on the structure and how the structure aligns itself for the secondary bonding forces. The alignment distinguishes a polymer from a fiber, elastomer or a plastic. Fibers are linear and have high symmetry. Elastomers have irregular structure and are flexible. Plastics are between fibers and elastomers. There are some structural differences between plastics, fibers, and elastomers, but some polymers can be used as plastics and fibers. Some examples are polypropylene and polyamides. The way these polymers are processed makes the distinction between a fiber and a plastic. If polypropylene is extruded then it is used as a fiber, but if the process is an injection molding then it is used as a plastic.

The Chemistry of Polymers

The term polymer is from the Greek terms: *polys* – many, and *meros* – part. Polymers consist of high molecular weight carbon atoms. They are long chain molecules composed of a large number of monomers. Typically, a linear polymer is composed of a

large number of repeating units with identical structure. Reaction 1 shows how a monomer unit breaks its double bond and forms a polymer in the polymerization process. The molecule in brackets is called the repeating unit with (n) number of repeating units.

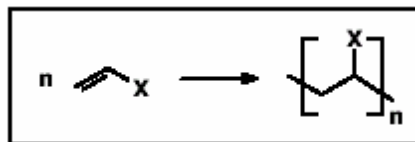

Reaction 1

Polymerization is the chemical reaction in which low-molecular-weight monomer with carbon – carbon bonds react to form polymers. The degree of polymerization is the number of repeating units linked in the polymerization process. Polymers formed from more than one type of monomer are called copolymers.

In condensation polymerization, the monomer linking occurs as a small molecule, often a water molecule splits off. The polymer made is from monomers with complementary reactive end groups. Reaction 2 shows how nylon 66 (carpet) is formed through condensation polymerization.

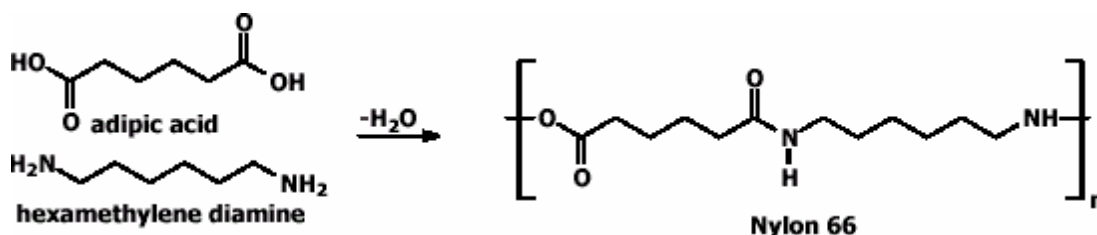

Reaction 2

Physical Properties

The physical properties of plastics help determine the applications and use of that plastic. The typical tests for polymers to use to compare one polymer to another are: tensile strength, glass transition temperature (T_g), elongation, and tear resistance. Precise equipment is used to measure properties such as tensile strength and glass transition temperature, but these properties can also be approximated with simple equipment.

Crystalline polymers have individual chains that are folded and packed regularly in an ordered fashion. The polymer chains are usually long; therefore the ordered arrangement is not perfect. Examples of crystalline polymers are polyethylene and polypropylene. Polypropylene is used in yarn for carpet, knitted fabrics and liners for disposable diapers. Polyethylene is used in packaging materials, in wire and cable insulation and milk cartons. Amorphous polymers have unordered regions. The polymer chains are arranged randomly and can be entangled. Polystyrene and polycarbonate are examples of amorphous polymers. Polystyrene is used in fast food packaging, egg containers, and mirror and picture frames. Polycarbonate is used in automobile taillight lenses, bumpers, and drapery fixtures. Figure 1 shows the point where the glass

transition temperature occurs for an amorphous polymer. Figure 2 shows the point where the glass transition temperature and melting temperature occurs for a crystalline polymer. By knowing the glass transition temperature of a polymer and the state of the polymer, then you will know at what temperature you should operate industrial processes or at what temperature you should blend two polymers together. If you try to blend a polymer below its T_g you will not be able to blend it because the polymer chains will not be able to move into new positions to relieve the stress that is being put in them.

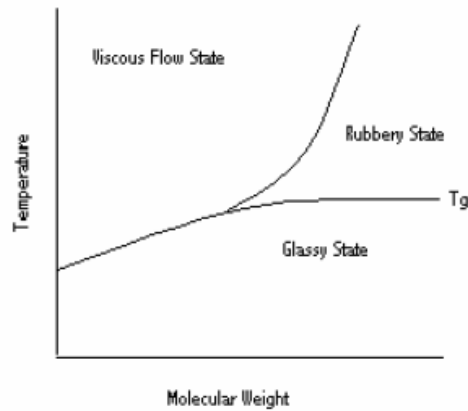

Figure 1: Amorphous Polymer Temperature - Weight Diagram

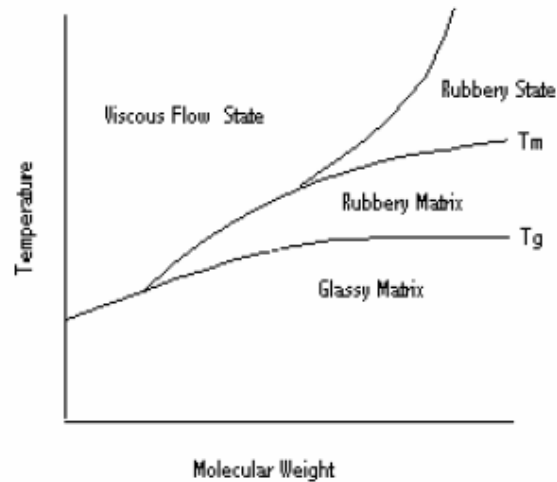

Figure 2: Crystalline Polymer Temperature - Weight Diagram

Plasticizers enhance the flow characteristics of polymers by decreasing their glass transition temperature. Tensile strength also generally decreases with addition of plasticizers. The process of plasticization of a solid polymer goes through a change from hard and brittle to hard and tough then to soft and tough. If the glass transition temperature is lowered then you can achieve certain states or regions of polymers at lower temperatures. An example of a use of a plasticizer is when changing a material such as PVC pipes to make car seat covers or raincoats.

Bioplastics

They are several natural occurring polymers that can be processed to form plastic. An example is starch. Starch is inexpensive, it can be plasticized with water to be used in many industrial processes, and the product from a starch-derived polymer is biodegradable. The limitation to starch formed products is poor water resistance and it does not have a lot of strength. Examples of starch – based products are trash bags, eating utensils and disposable golf tees.

Plastics can also be processed from resins that were polymerized by naturally occurring monomers. An example that is being developed and marketed today is poly (lactic acid). It can also, like starch, be processed using the same industrial processes as fossil fuel products.

Industrial and Environmental Issues

Facing the inevitable exhaustion of fossil fuels such as petroleum, both government and industry are seeking alternatives to ease our reliance upon oil. Plastic has become a staple of the modern industrial world, and most of it is currently petroleum (crude oil) based. In fact, our use of plastics in the past century has grown along with our consumption of oil. From ink pens to medical syringes, contact lenses to computer housings – plastic is indeed the material of the age.

As such a popular material, plastic fills our landfills (in various forms from packaging to appliances). As its base ingredients are becoming scarcer, new and better ways of manufacturing plastics are being researched. The most promising way of making plastic from other, renewable, abundant material such are corn, soy beans, gelatin, etc. is the avenue of bioplastics. Researchers in bioplastics intend to prove that there are abundant, environmentally friendly materials from which to make non-oil based plastic. Bioplastics provide a wide range of mechanical properties, and in many cases they are biodegradable. This cuts the cost of storing, or disposing of discarded plastic considerably.

Combining plasticizers with a biopolymer makes basic bioplastics. Once this has been mixed together in a liquid solution, the solution is allowed to cool and harden. The end result is a bioplastic. This new plastic will have differing characteristics depending upon the ratio of plasticizer to biopolymer present. Plastics are easily designed for specific functions by varying the ingredients and their relative amounts.

Some of the challenges facing bioplastics:

1. Economically Unfeasible
2. Biodegradability is a useful and a not-so-useful property
3. The energy it takes to manufacture bioplastics still comes from standard petroleum sources, undercutting the goal of bioplastics
4. Current bioplastics don't have the properties that make plastic so useful (malleability, pliability, etc.).

Pre-Lab Tasks

Answer the following questions:

1. A friend asks, "What the heck is a bioplastic anyway and why should I care about?"
How would you answer your friend?

BIOPLASTIC = biopolymer(s) + plasticizers(s) + other additive(s)

2. Why are physical properties important for bioplastics? What are they?

The physical properties of plastics help determine the applications and use of that plastic. The typical tests for polymers to use to compare one polymer to another are: tensile strength, glass transition temperature (T_g), elongation, and tear resistance. Precise equipment is used to measure properties such as tensile strength and glass transition temperature, but these properties can also be approximated with simple equipment.

3. What is a plasticizer? Why is it important?

Plasticizers enhance the flow characteristics of polymers by decreasing their glass transition temperature. Tensile strength also generally decreases with addition of plasticizers. The process of plasticization of a solid polymer goes through a change from hard and brittle to hard and tough then to soft and tough. If the glass transition temperature is lowered then you can achieve certain states or regions of polymers at lower temperatures. An example of a use of a plasticizer is when changing a material such as PVC pipes to make car seat covers or raincoats.

4. Describe polymerization....what does it mean?

Polymerization is the chemical reaction in which low-molecular-weight monomer with carbon – carbon bonds react to form polymers. The degree of polymerization is the number of repeating units linked in the polymerization process. Polymers formed from more than one type of monomer are called copolymers.

5. What are some challenges that bioplastics face that keeps them from dominating the industry?

Some of the challenges facing bioplastics:

5. Economically Unfeasible
6. Biodegradability is a useful and a not-so-useful property
7. The energy it takes to manufacture bioplastics still comes from standard petroleum sources, undercutting the goal of bioplastics
8. Current bioplastics don't have the properties that make plastic so useful (malleability, pliability, etc.).

Making and Testing Two Bioplastics

Safety Checklist

- Proper attire is worn (long pants and closed-toe shoes).
- Food and drinks are stored and consumed outside the laboratory.
- Lab coat and safety glass are worn.
- Latex or nitrile gloves are used when handling samples and chemicals.
- Insulated gloves are used when handling hot materials.
- Ear protection is used when a procedure involves loud noises.

Problem Statement

For your experiment, first (1), you will create your own bioplastics from two different polymer bases (gelatin: protein and starch, a polysaccharide). Next (2), you will test your bioplastic to check its material properties.

Creating and testing a protein-based polymer bioplastic: gelatin

Background

The first bioglass recipe makes transparent sheets that can be used for replacing the glass in your picture frames. It has a small amount of a plasticizer in it, therefore, it will not be as flexible and its glass transition temperature will be different than that of a polymer with a large amount of plasticizers. The plasticizer is the water and glycerol mixture and the polymer is the gelatin. The polymer to plasticizer ratio is *typically* 4:1. Glycerol (or glycerin, glycerine) is a simple polyol compound. It is a colorless, odorless, viscous liquid that is widely used in pharmaceutical formulations. Glycerol has three hydrophilic hydroxyl groups that are responsible for its solubility in water and its hygroscopic nature. The glycerol backbone is central to all lipids known as triglycerides. Glycerol is sweet-tasting and of low toxic. Due to humidity conditions, the amount of plasticizer can be increased or decreased so that the bioplastic works for the intended "environment".

Pre-experiment 1 Checklist

Materials

- 1 glass heating flask/beaker or a pot
- 1 set of metal measuring spoons or a glass graduated cylinder
- 1 pair of scissors (optional)
- 12.6g (2 tsp) of glycerol

100 ml water
12.0g (4tsp) of gelatin
1 large metal spoon
Hot plate or Bunsen burner
25cm x 15cm brownie/loaf pan or dish (preferable nonstick for clarity)
Sandpaper or file or scissors
*Access to a refrigerator and freezer

Procedure 1a

Making Bioglass

1. Measure out 100ml of (1%) glycerol solution
2. Add 12.0g of gelatin to glycerol solution
3. Stir this mixture.
4. Heat the mixture until a slight bubbly film occurs on the surface (slightly before boiling, approx. 95 C).
5. Remove heat and stir again so there are no lumps.
6. Wait for two to three minutes to allow froth to collect upon mixture surface.
7. Remove froth with a spoon; try to leave as much clear fluid in pot as possible.
8. Pour clear liquid into desired mold (pan).
10. Once liquid solidifies, remove mold (30-60 min.)
11. Trim solid plastic as needed (scissors are acceptable if plastic is still slightly soft, sand paper or a file may be appropriate if mold is very hard).

Data Analysis

1. Compare your plastic to other plastics. What are differences and similarities?
2. Does your plastic scratch easier than other plastics? Why or why not?
3. Can you see light through it?
4. How flexible is it? Compare the flexibility of your plastic to plastic bottles or plastic wrap.

Procedure 1b

Testing Bioglass

Now, you can perform tests on your bioplastic. You will attempt to determine the glass transition temperature of your bioplastic. Normally, the glass transition temperature, T_g , is obtained using a differential scanning calorimeter. You have a blank reference pan and another pan with the polymer in it. A set point temperature is chosen and then the polymer is heated to that set point. Then the heat flow versus the temperature is plotted to see when the change in heat flow increases rapidly and that is the T_g of the polymer. Since you do not have access to this piece of equipment you will use another method. It will not be an accurate measurement, but you can get an idea of what the temperature might be by seeing if it is higher or lower than the temperature in a refrigerator or freezer.

Lab Procedure

1. Take a sample of the bioglass made in section 1a.

2. See if it is flexible at room temperature.
3. Put your sample in the refrigerator.
4. If your sample is brittle after leaving in the refrigerator for 15 minutes, then the T_g is between the room temperature and the refrigerator temperature.
5. If your sample is still flexible at the refrigerator temperature, place in the freezer for 15 minutes and then check its flexibility.
6. If your sample is brittle at the freezer temperature, then the T_g is between the refrigerator temperature and freezer temperature.
7. If your sample is still flexible at the freezer temperature, then your bioplastic's T_g is lower than the freezer temperature.

Data Analysis

1. Is your sample flexible at room temperature?
2. If answer to #1 is yes, then is your sample brittle after being in the refrigerator for 15 minutes?
3. If answer to #2 is no, then is your sample brittle after being in the freezer for 15 minutes?
4. After answering these questions, what do you conclude from the glass transition temperature test about your sample?

Creating and testing bioplastic from a carbohydrate-based polymer: cornstarch

Background

There is more carbohydrate on earth than all other organic material combined. Polysaccharides are the most abundant type and make up around 75% of all organic matter. The most plentiful is cellulose, found in plant cell walls. Starch is also a very abundant component of the planet's biomass. It is found in corn, potatoes, wheat, tapioca, rice, sorghum, barley, peas, etc. The two major polymer components of starch are amylose and amylopectin. Cornstarch is typically 28% amylose and 72% pectin. You will be making and testing a "generic" bioplastic from cornstarch, water, glycerin, acetic acid (vinegar), and water.

Pre-experiment Checklist

- 1 glass heating flask/beaker or a pot
- 1 set of metal measuring spoons or a glass graduated cylinder
- 1 pair of scissors (optional)
- 3g glycerol
- 80ml water
- 11g Acetic acid (vinegar)
- 10g corn starch
- 1 large metal/silicon spoon/stirrer
- Hot plate or Bunsen burner
- 25cm x 15cm brownie/loaf pan or dish (preferably nonstick for clarity)
- Sandpaper or file or scissors
- *Access to a refrigerator and freezer

Procedure 2a

Making another bioplastic

1. Pour 80 ml of water into a 200-500ml beaker and place on top of a stir plate.
2. Put in the corn starch and stir vigorously with a spoon/stir rod until a homogenous white, even suspension occurs.
3. Mix in the glycerin and mix thoroughly.
4. Mix in the vinegar.
5. Stir mixture so that it is thoroughly mixed.
6. Turn on the heat to about a level 3, and allow the mixture to begin to turn into "thick goo". The polysaccharide has long sugar molecule and the vinegar breaks this up, and because we added glycerol, which acts as a plasticizer it won't be as brittle.
7. Heat a bit longer and it becomes clearer.
8. At this point you can pour onto the top of a cookie sheet and allow it to flow down a bit so that it spreads out a bit. It will be simply to a "jello" type of consistency.
9. Let it sit for a while and "gel".

Procedure 2b

Testing Bioplastic

Now, you can perform tests on your bioplastics as you did in procedure 1b.

Lab Procedure

1. Take a sample of the bioglass made in section 2a.
2. See if it is flexible at room temperature.
3. Put your sample in the refrigerator.
4. If your sample is brittle after leaving in the refrigerator for 15 minutes, then the T_g is between the room temperature and the refrigerator temperature.
5. If your sample is still flexible at the refrigerator temperature, place in the freezer for 15 minutes and then check its flexibility.
6. If your sample is brittle at the freezer temperature, then the T_g is between the refrigerator temperature and freezer temperature.
7. If your sample is still flexible at the freezer temperature, then your bioplastic's T_g is lower than the freezer temperature.

Data Analysis

1. Is your sample flexible at room temperature?
2. If answer to #1 is yes, then is your sample brittle after being in the refrigerator for 15 minutes?
3. If answer to #2 is no, then is your sample brittle after being in the freezer for 15 minutes?
5. After answering these questions, what do you conclude from the glass transition temperature test about your sample?
6. Note differences between your two bioplastics? What do you conclude?

Compression Molding: Creating and processing a soy-based bioplastic product
Creating and testing bioplastic from a carbohydrate-based polymer: cornstarch

Background

Compression molding is a method of molding in which the molding material, generally preheated, is first placed in an open, heated mold cavity. The mold is closed with a top force or plug member, pressure is applied to force the material into contact with all mold areas, while heat and pressure are maintained until the molding material has cured. Compression molding was first developed to manufacture composite parts for metal replacement applications; compression molding is typically used to make larger flat or moderately curved parts. This method of molding is greatly used in manufacturing automotive parts such as hoods, fenders, scoops, spoilers, as well as smaller more intricate parts. The material to be molded is positioned in the mold cavity and the heated platens are closed by a hydraulic ram. The mold is then cooled and the part removed. Materials are heated above their melting points, formed and cooled. The more evenly the feed material is distributed over the mold surface, the less flow orientation occurs during the compression stage.

In compression molding there are six important considerations that an engineer should bear in mind:

- Determining the proper amount of material.
- Determining the minimum amount of energy required to heat the material.
- Determining the minimum time required to heat the material.
- Determining the appropriate heating technique.
- Predicting the required force, to ensure that shot attains the proper shape.
- Designing the mold for rapid cooling after the material has been compressed into the mold.

Pre-experiment Checklist

KitchenAid Mixer
15 ton Compression Molder
Mold (cavity)
Scale Balance
Weight boats
Beaker(s)
Magnetic Stirrer
Soy Protein Isolate
Glycerol
Water
Sodium Sulfite
Potassium salt
Mixing bowl
Spoon(s)
1 quart of water

Procedure 1

Making another bioplastic

1. Soy-based Bioplastic "Inputs" Calculation

100 parts Soy Protein Isolate (start with 250g)
30 parts Glycerol _____ **75** _____ g
50-60 parts Water _____ **125-150** _____ g
0.5 parts Sodium Sulfite _____ **1.25** _____ g
0.5 parts Potassium Salt _____ **1.25** _____ g

Lab Procedure

1. Place a 400-600ml or larger beaker on top of a stir plate
2. Add the Sodium Sulfite and the Potassium Salt
3. Add the water
4. Add the glycerol
5. Add the magnetic stirrer & turn on the stir plate (low-med). Leave to stir for about 5 minutes
6. In the KitchenAid mixing bowl, add the Soy Protein Isolate(500g)
7. Turn the mixer on a VERY SLOW SPEED and begin to add the wet mixer from the beaker into the mixing bowl and into the Soy Protein Isolate
8. You may need to turn the mixer off to scrape the sides with a spoon & continue mixing
9. NO CLUMPS! Mix until a homogeneous/smooth mixture is obtained
10. Spray the mold cavity provided with Silicon lubricant.
11. Slowly...very slowly remove the mixing bowl by removing it from the side clamps gently, and it should unhook from the back as well. This can be a messy cleanup if done too fast and too hard (force).
12. Carefully spoon the mixture into the mold cavity to about 1/6" from the top.

Procedure 2 – Continuing toward product production

Compression molder processing: manual operation procedure

1. Check for any debris around the molder or inside the front gate.
2. Check electrical and mechanical connections.
3. Ensure that safety shields and gates are closed.
4. Ensure safety latch/disconnect switch on the right/northwest top edge of molder is turned to the "ON" position. Molder will not run if it is "OFF".
5. Check the oil reservoir indicated gauge on back, middle side of the molder.. If it is in the "GREEN" area the molder can be used. If the gauge indicates either "YELLOW" or "RED" contact the lab supervisor or undergraduate personnel. The molder is NOT ready for operation. The reservoir is Chevron Rando HDISO 46, and the tank holds approximately 15 gallons (approved by Wabash). The oil is pumped through a 10

- micron absolute filter element. DO NOT pour oil directly into the reservoir, but pumped through the filter cart to the fill, full mark on the oil level gauge.
6. Turn on the inlet and outlet water valves located along the west, green wall to the "ON" positions. You will hear the water running through the pipes.
 7. Turn air "yellow" valves located on the back of the compression molder's top platen manifold. Turn both valves to "ON" position. You will hear the air come on.
 8. Check that the air pressure regulator (west, green wall) reads below the water pressure (top of platen manifold).
 9. Close the front safety gate.
 10. Press the "CONTROL POWER ON" pushbutton and it will illuminate.
 11. Press the "HYDRAULIC ENABLE ON" pushbutton and it will illuminate.
 12. Select the "MANUAL" position of the "MAN/SEMIAUTO" selector switch.
 13. Press the "PLATEN HEAT ON" pushbutton and it will illuminate.
 14. Adjust the PLATEN 1 AND PLATEN 2 on the upper right corner of the control panel temperature to the desired cure temperature, 300°F. Push the up and down arrows to set temperature and push enter button in the lower right corner. This will allow the red light to disappear and set the temperature.
 15. Allow platens to heat up to the desired temperature.
 16. Once the temperature has been reached, place the mold on the lower platen of the compression molder.
 17. Close the clamp by simultaneously depressing and holding the dual "CLAMP CLOSE" push buttons. The clamp will close at a rapid speed until the "SLOWDOWN" proximity switch is actuated.
 18. When the "SLOWDOWN" proximity switch is actuated, the "CLAMP SEALED" light illuminates, indicating that the operator may release the "CLAMP" CLOSE PUSH BUTTONS. The clamp will continue to build pressure to the setting of the panel mounted adjustable relieve valve. The pump runs continuously to maintain this pressure setting.
 19. Set the pressure for 15 tons.
 20. For platen cooling continue through the following steps.
 21. Pull the "AIR" push/pull button to activate the "AIR COOLING" feature. This will energize the air solenoid valve and illuminate the "AIR" light. The heat relays will also be de-energized.
 13. We will use a Cure Time of 7 minutes.
 14. After 7 minutes as elapsed, pull the blue "WATER ON" push/pull button.
 15. Allow compression molder to cool down to around 60-70°F.
 16. When the platen temperature drops to the desired level, push the blue "WATER ON" push/pull button to turn the "WATER COOLING" off. This will de-energize the water solenoid and extinguish the "WATER ON" light.
 17. Open the clamp by depressing and holding the "CLAMP OPEN" pushbutton. The "CLAMP SEALED" light will de-energize and the clamp will open until the pushbutton is released or the "CYCLE RESET" proximity switch is actuated.
 18. When the "CYCLE RESET" proximity switch is actuated, the press is ready for another cycle.

19. As a precaution: USE HOT GLOVES to remove the mold from the bottom platen, and place on "on table beside the compression molder.
20. Begin removing top of mold with two screw drivers to pry both ends up.
21. Continue removing mold from final bioplastic product you've produced.

Data Analysis

1. Is your product flexible, brittle, or hard? Describe your final product.
2. How would you improve your product in the future? What would make it better?

Sodium sulfite (sodium sulphite) is a soluble sodium salt of sulfurous acid. It is a product of sulfur dioxide scrubbing, a part of the flue gas desulfurization process. It is also used as a preservative to prevent dried fruit from discoloring, and for preserving meats, and is used in the same way as sodium thiosulfate to convert elemental halides to their respective acids, in photography and for reducing chlorine levels in pools

Potassium salt is a substitute for regular table salt (sodium-chloride) that contains only half of the amount of sodium as table salt. It is known as a "half-salt" substitute and provides all of the seasoning and flavoring benefits of regular salt without all of the bad side effects, such as high blood pressure. There are certain people that are more at-risk of these side effects than others. These people should take the necessary precautions (replacing table salt with potassium salt) to prevent these serious health risks from occurring.

Glycerol is a syrupy, sweet, colorless or yellowish liquid, $C_3H_8O_3$, obtained from fats and oils as a byproduct of saponification and used as a solvent, an antifreeze, a plasticizer, and a sweetener and in the manufacture of dynamite, cosmetics, liquid soaps, inks, and lubricants.

Soy protein isolate is a highly refined or purified form of soy protein with a minimum protein content of 90% on a moisture-free basis. It is made from defatted soy flour which has had most of the non-protein components, fats and carbohydrates removed. Because of this, it has a neutral flavor and will cause less flatulence due to bacterial fermentation. Soy isolates are mainly used to improve the texture of meat products, but are also used to increase protein content, enhance moisture retention, and as an emulsifier. Flavor is affected, but whether it is an enhancement is subjective. Before 2006, the U.S. Food and Drug Administration (FDA) was examining flavor reversion concerns related to levels of the toxin furan in soy protein isolate and other foods.[5] This problem has been solved by David Min of the Ohio Agricultural Research and Development Center. The chlorophyll in soy oil was reacting in the presence of light to form trans-2-heptenal and 2-pentenylfuran. Chlorophyll in soy oil is now removed with diatomaceous earth filters. Pure soy protein isolate is used mainly by the food industry. It is sometimes available in health stores or in the pharmacy section of the supermarket. It is usually found combined with other food ingredients.

Background

Milk contains many molecules of a protein called casein. Each casein molecule is a monomer and a chain of casein monomers is a polymer. The polymer can be scooped up and molded, which is why plastic made from milk is called casein plastic.

Pre-experiment 1 Checklist

Making Casein

Materials

- 1 600ml beaker
- 1 Graduated cylinder
- 1 Magnetic stir rod
- 1 Heated stir plate
- 45.5g Powdered skim or 480ml skim milk
- 444.5g of water (if using powdered milk)
- 40ml of vinegar (30ml for skim milk)
- 1 strainer
- 1 pair of heat resistant gloves

Procedure 3a

Powdered Milk

1. In a 600ml beaker measure out 444.5g of water
2. In a separate container measure out 45.5g of the powdered skim milk
3. In a graduated cylinder measure out 40ml of vinegar
4. Stir the water and slowly add the powdered milk (add 1-2 drops of food coloring if desired at this point)
5. Heat the mixture to 70 C°
6. Remove the thermometer and add the vinegar
7. Take the beaker off of the hot plate and strain out the precipitates
8. Shape, cut and mold into desired shape
9. Allow the molded product to dry and set over the next few days.

Procedure 3b

Skim milk

1. Measure out 480ml of milk (add 1-2 drops of food coloring if desired at this point) and approximately 30ml of vinegar
2. Stir and heat the milk until it reaches approximately 70 C
3. Remove the thermometer and add the vinegar
4. Take the beaker off of the hot plate and strain out the precipitates
5. Shape, cut and mold into desired shape
6. Allow the molded product to dry and set over the next few days

Data Analysis

1. Is your product flexible, brittle, or hard? Describe your final product.
2. How would you improve your product in the future? What would make it better?

Sodium sulfite (sodium sulphite) is a soluble sodium salt of sulfurous acid. It is a product of sulfur dioxide scrubbing, a part of the flue gas desulfurization process. It is also used as a preservative to prevent dried fruit from discoloring, and for preserving meats, and is used in the same way as sodium thiosulfate to convert elemental halides to their respective acids, in photography and for reducing chlorine levels in pools

Potassium salt is a substitute for regular table salt (sodium-chloride) that contains only half of the amount of sodium as table salt. It is known as a “half-salt” substitute and provides all of the seasoning and flavoring benefits of regular salt without all of the bad side effects, such as high blood pressure. There are certain people that are more at-risk of these side effects than others. These people should take the necessary precautions (replacing table salt with potassium salt) to prevent these serious health risks from occurring.

Glycerol is a syrupy, sweet, colorless or yellowish liquid, $C_3H_8O_3$, obtained from fats and oils as a byproduct of saponification and used as a solvent, an antifreeze, a plasticizer, and a sweetener and in the manufacture of dynamite, cosmetics, liquid soaps, inks, and lubricants.

Soy protein isolate is a highly refined or purified form of soy protein with a minimum protein content of 90% on a moisture-free basis. It is made from defatted soy flour which has had most of the non-protein components, fats and carbohydrates removed. Because of this, it has a neutral flavor and will cause less flatulence due to bacterial fermentation. Soy isolates are mainly used to improve the texture of meat products, but are also used to increase protein content, enhance moisture retention, and as an emulsifier. Flavor is affected, but whether it is an enhancement is subjective.

Before 2006, the U.S. Food and Drug Administration (FDA) was examining flavor reversion concerns related to levels of the toxin uran in soy protein isolate and other foods.^[5] This problem has been solved by David Min of the Ohio Agricultural Research and Development Center. The chlorophyll in soy oil was reacting in the presence of light to form trans-2-heptenal and 2- pentenyfuran . Chlorophyll in soy oil is now removed with diatomaceous earth filters.

Pure soy protein isolate is used mainly by the food industry. It is sometimes available in health stores or in the pharmacy section of the supermarket. It is usually found combined with other food ingredients.